

Fagus-GreCon
Greten GmbH & Co. KG

P.O. Box 1243
D-31042 Alfeld-Hanover

Phone +49 (0) 5181-79-0
Fax +49 (0) 5181-79-229
E-Mail sales@grecon.com
www.grecon.com

GreCon

Inline Delamination
Detection with the
Ultrasonic Measuring
System

GreCon
Measuring
Technology

GreCon
Fire
Protection



EN | R.01 | 2013.04
Subject to technical and country-specific modifications.
© Fagus-GreCon Greten GmbH & Co. KG

UPU 6000

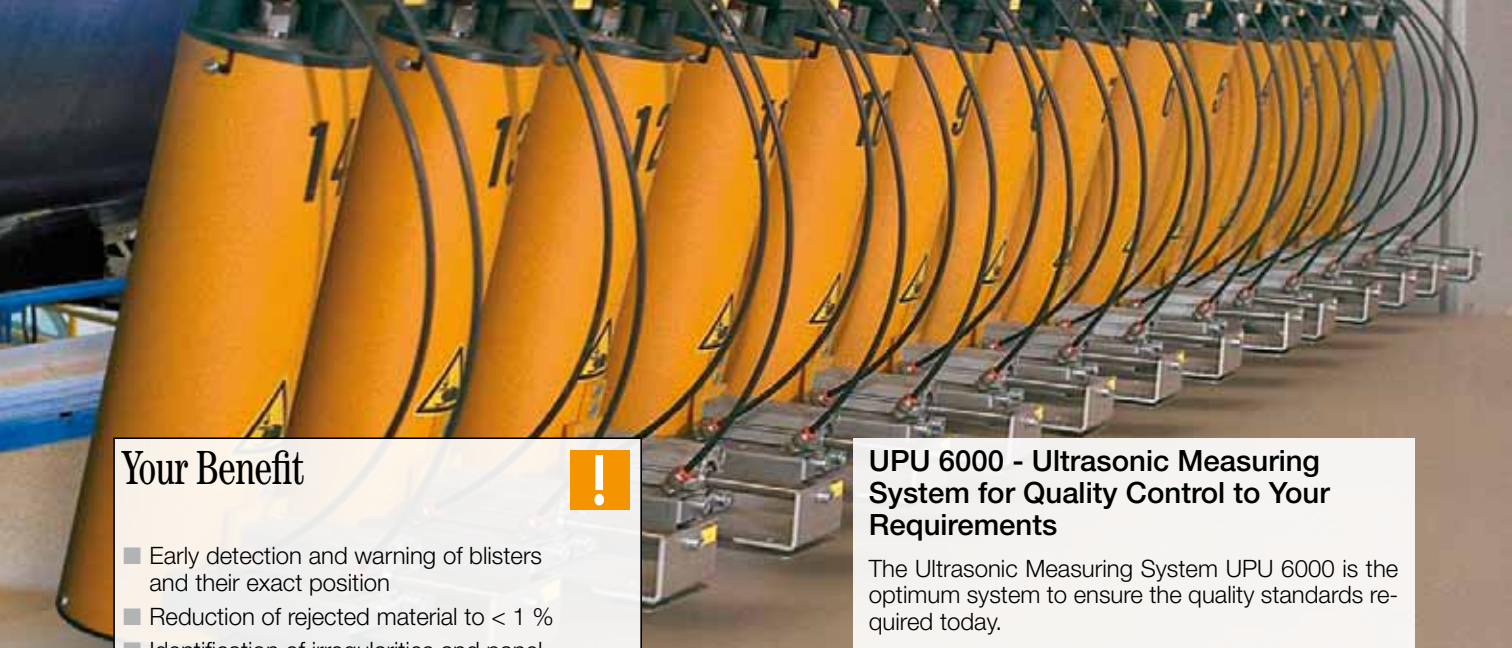

Your Benefit



- Early detection and warning of blisters and their exact position
- Reduction of rejected material to < 1 %
- Identification of irregularities and panel homogeneity during production
- Process trending = quick rectification = production costs savings
- Optimisation of pressing times
- Quick production change-over
- Realise reserve capacities and hidden costs

Why GreCon



- Fast and early detection of quality fluctuations
- Realise optimisation potentials by visualising the effects of changes in the production process (intentional or unintentional)
- With ct-frame: adjustment, service and maintenance during running production
- High availability with ct-frame and minimal maintenance expense
- Expanded application range
- Automatic adjustment of recipe parameters for transmitter/receiver components

UPU 6000 - Ultrasonic Measuring System for Quality Control to Your Requirements

The Ultrasonic Measuring System UPU 6000 is the optimum system to ensure the quality standards required today.

The integrated early blow detection reduces and eliminates the production of blows and as a result reduces customer complaints.

Process trending allows cost-optimised production of high-quality wood based panels, substandard panels are immediately detected.

Application areas can be monitored by innovative GreCon technology where only special solutions were available in the past. Blisters can now be detected in panels of thicknesses of up to 55 mm and in light panels (< 550 kg/m³).

With automatic adjustment of system-specific recipe parameters, the ultrasonic measuring system can be parameterised without prior knowledge. This ensures optimum configuration of the ultrasonic measuring system at any time.

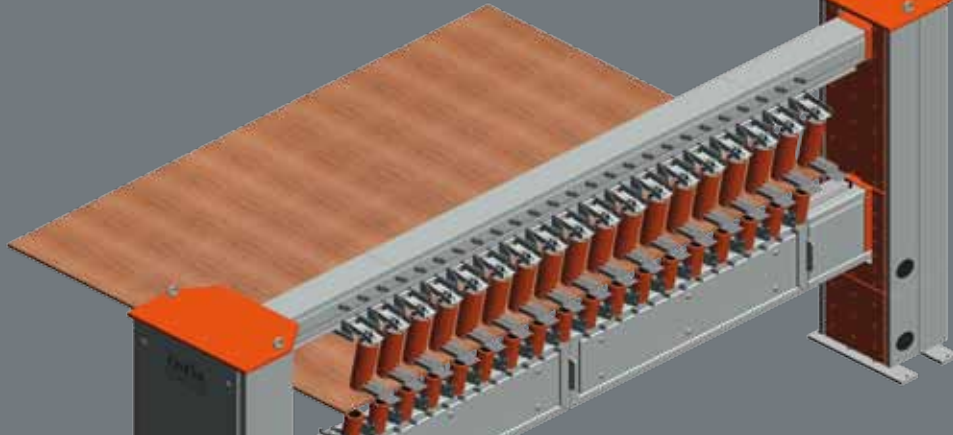

Design and Construction of the System

Up to 24 inspection channels can be mounted on a steel frame. The closed frame concept protects all components, such as cable and air channels, transmitter electronics or compressed air lines, against surrounding environment.

A modification of the roller conveyor (panel guidance) is only necessary in individual cases since the inspection channels have a maximum installation depth of 200 mm. Easily accessible inspection flaps allow access to the core of the measuring system at any time.

Ceramic transmitters, which are installed below the material being measured, generate the necessary ultrasonic energy. The emitted ultrasonic signal penetrates the material. The receivers installed above the material receive and evaluate the ultrasonic signal.

A hinged mechanism protects the receivers against damage or mechanical misalignment from big blisters.

Blow Detection

The UPU 6000 has integrated blow detection for final quality control and sorting of the measured panels. If blows occur, their size and location is clearly represented. The defective panels are marked, and a signal is given to allow them to be identified for rejection. Different blow definitions allow a graded quality sorting.

With the quality of the measuring results dependent on consistent conditions during measurement, the GreCon Ultrasonic Measuring System is equipped with an adjustment function. The inspection channels can be checked and re-adjusted. The electronic adjustment can be conducted in panel gaps during the production.

- Integrated pneumatic and electronic supply ①
- Easily accessible inspection flaps ②
- Minimum installation depth of 200 mm, modification of roller conveyor only in exceptional cases ③
- Automatic calibration unit ④

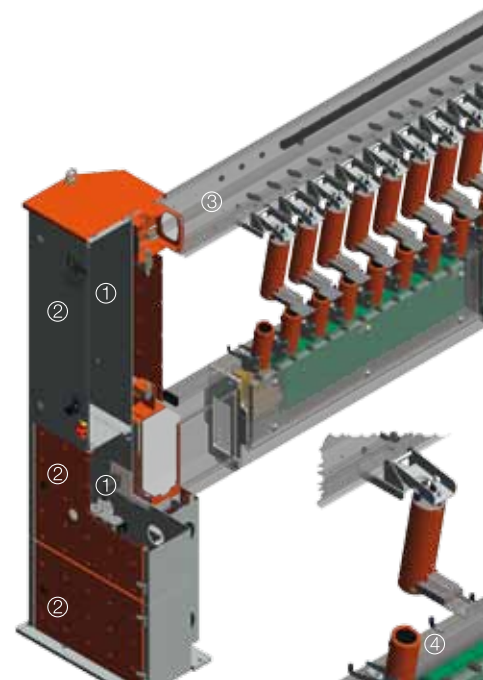

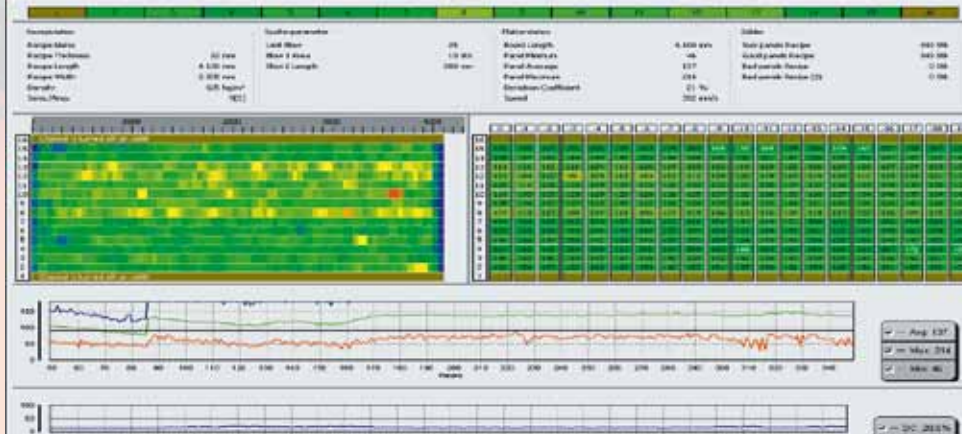

Process Optimisation

Get the maximum out of your production with the process optimisation option. With this option, the resolution of the measured data is increased so that influences affecting the production process can be detected even faster.

The improved resolution of measured values requires a special method to adjust the inspection channels: A defined reference sample, which guarantees an exact adjustment is required for the resolution of 250 colours and placed between transmitter and receiver.

The system is equipped with an automatic dust accumulation control which is activated at predetermined intervals after calibration. This is done in the

gap between two panels and does not disturb the measuring process. If the values of an inspection channel strongly deviate from the reference value, a warning signal is sent to the operator. If the degree of dust accumulation exceeds the limiting value, the next maintenance interval is indicated to the operator.

Using the high-resolution trend analysis calculation from the measured values, the plant operator is able to prevent the production of blister or blown panels. This way, the production of rejects can be avoided and the production speed increased. The signal detected by the ultrasonic receivers is influenced by changes in important process parameters, such as press factors, density or material moisture. These process parameters directly influence the quality of a panel.

①

②

③

④

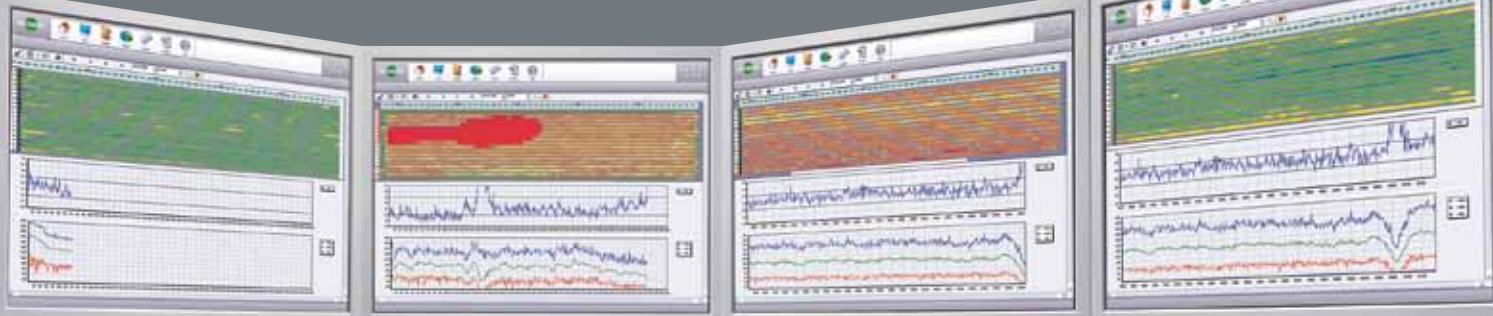

Production Flow

① Starting process

The starting process can be stabilised and optimised to the required speed over a production period of about 30 panels. The minimum value and the average value clearly show the stabilisation of the panel quality. This fact and the reduced risk of blisters are also represented in a declining DC value (see software functions).

② Change in speed

In the last third of the observation period, the production speed was continuously increased by up to 11 %. The increasing risk of blisters can be clearly seen from the increasing DC value. The production process can be tuned to the blister limits. A maximum capacity workload is ensured.

③ + ④ Change in moisture

A clear increase in material moisture leads to a negative peak of all quality indicators in the long-term graphic. The DC value jumps into the blister area. The second picture shows the normalisation of the production process after passage of the moist material. The maximum allowed steam pressure in the panel centre, before blisters occur, can be seen by using the visualisation trend indicators.



ct-Frame

To achieve continuous system availability, the UPU 6000 can be equipped with a ct-frame. This basic construction of the measuring system makes an installation after saws or in continuous productions possible. The system can be calibrated and adjusted at any time by moving the ct-frames sideways out of the production line. Maintenance, diagnostics and repairs can be conducted during production.

The mobile construction of the system allows for an escape run in the case of large blisters and prevents the measuring system from being damaged.

Extended Application Range

An extended range of transmitter and receiver components now allows the measurement not only of standard products of the wood based panel industry, but also of special products, such as wood based panels of a thickness of up to 55 mm at a normal density of 550 kg/m³.

The measurability of any panel-shaped material can be verified in our own test laboratory. After testing, you will receive an evaluation report showing the system's capabilities.

User-Friendly, Simple, Robust and Accurate

High availability, operational reliability and, above all, consistent measuring quality are ensured by the calibration with integrated self-diagnosis system and the construction of the system with a ct-frame. This leads to high confidence in the system and acceptance by the operator.

The automatic adjustment and integrated dust accumulation control ensure that measurements are independent of surrounding industrial environment. It is only a matter of an adjustment of each inspection channel that ensures a continuously reliable measurement. It ensures that the represented information is a reliable basis to regulate and optimise production processes. With the measuring conditions of the inspection channels remaining consistent, it is possible to go beyond a simple yes/no statement and to optimise the process using the intelligent, newly developed parameters.

OPC Konfiguration

Reihenfolge	OPC Item	Standard	Wert	Unit	Status
1	Injektionsdruck	OPU (Modul) 124024	1.0000	0 [0.0 7.04.04.2012 10.00.00.230]	●
2	In-Rezepturen-Zeichen 1 = 2	OPU (Modul) 1240103	1.0000	0 [0.0 7.04.04.2012 10.00.00.230]	●
3	In-Rezepturen-Zeichen 3 = 4	OPU (Modul) 1240104	1.0000	0 [0.0 7.04.04.2012 10.00.00.230]	●
4	In-Rezepturen-Zeichen 5 = 6	OPU (Modul) 1240105	1.0000	0 [0.0 7.04.04.2012 10.00.00.230]	●
5	In-Rezepturen-Zeichen 7 = 8	OPU (Modul) 1240106	1.0000	0 [0.0 7.04.04.2012 10.00.00.230]	●
6	In-Rezepturen-Zeichen 9 = 10				
7	In-Rezepturen-Zeichen 11 = 12				
8	In-Rezepturen-Zeichen 13 = 14				
9	In-Rezepturen-Zeichen 15 = 16				
10	In-Rezepturen-Zeichen 17 = 18				
11	In-Rezepturen-Zeichen 19 = 20				
12	In-Recipe-Korrektur				
13	In-Recipe-Parierhöhe	Out-Swert-Lin			

Werte aktualisieren Aktivieren Schließen

Software Functions

■ Software

The visualisation software of all GreCon measuring systems is based on Windows. The software of the UPU 6000 consists of the following program modules:

■ Network Connection

For the data transmission to higher-ranking process control systems, different network connections, such as OPC or Profibus, are available.

■ Visualisation

The core of the software package is the visualisation software. It records, stores and graphically represents all measured data.

The simple menu structure, which is identical for all GreCon measuring systems, provides intuitive and user-friendly operation. Clear information and graphics quickly show changes in the production process to the operator. This enables him to take suitable countermeasures.

The measured panels are graphically represented in up to 5 or 250 colours, depending on the configuration of the system. The colour balance provides information on the quality and homogeneity of the panels after pressing.

■ Recipe Management

This is a product database in which different panel types and production parameters can be stored.

When entering parameters for individual recipes, suggestions are given on the adjustment of system-specific recipe parameters, such as transmitting voltage and sensitivity. An additional function allows calculation of system-specific recipe parameters by automatic algorithms. In this way, the optimum adjustment of the ultrasonic measuring system can be found at low expense and without prior operator knowledge of the parameters.



■ Quality Indicator

A clear indication of the current panel quality is the quality indicator. All measured values of a panel are compressed and represented as a quality key on a scale, similar to a speedometer.

■ Long-Term Graphic

To represent the trend of the panel quality, the maximum value, the average value and the minimum value of a panel are shown in a long-term graphic. Influences on the production process, such as moisture and temperature fluctuations or changes in production speed, are understood.

■ DC Long-Term Graphic (Deviation Control)

The DC value provides information on how homogeneous the panel was produced. The higher the

DC value, the more inhomogeneous production, the higher the probability for blisters to occur. The DC value indicates technical problems with glueing, spreading, pressing, or similar upstream processes.

■ Database

The database stores the measured values, thus allowing to call up the panels produced from history for analysis at any time. The data can be exported to other file formats for additional processing and evaluation.

■ Report Function

The report function allows automatic production of, for example, shift or production reports for freely definable time periods.

- ① UPU visualisation software with long-term and DC trending
- ② Report on production trend
- ③ Recipe management to enter and store recipes



Service

GreCon measuring systems are equipped with Gre-Con online support SATELLITE. This provides safe, simple and fast remote support when there is trouble or to check the system. Each online support is logged and stored in the system's history.

Technical Specifications

- Supply voltage..... 230 V / 115 V
- Frequency 50 Hz / 60 Hz
- Power consumption750 VA

- Compressed air supply.....6 bar / 90 ps
- Compressed air consumption.... approx. 145 l/h/
0.1 cfm
- Max. number of inspection channels
per electronics evaluation24
- Panel thickness 1 to 55 mm / 0.04 to 2.17 in
- Conveying velocities . max. 250 m/min / 750 fpm
- Minimum detectable defect size..... 25 x 25 mm
0.98 in x 0.98 in
- Diameter of measuring spot.....50 mm / 2 in
- Mechanical width
per inspection channel..... 110 mm / 4.33 in
Deviations on demand

Adjustment

To operate the UPU 6000 independent of surrounding environment, it is equipped with an automatic adjustment process to ensure that the UPU 6000 supplies precise measured values all the time. The fluctuations in surrounding environment are compensated for by fully automatic sensor adjustments. The highest possible resolution of 250 colours (process optimisation option) requires a high-precision method for adjustment using homogeneous calibration samples that are automatically placed between transmitter and receiver. This calibration method guarantees, for example, that rounds in the continuous press steel belt become visible in the ultrasound picture. The method fulfils highest requirements of ultrasonic detection to optimise production processes.

Service experts are available worldwide





References

The UPU 6000 is used in the following applications:

- MDF board
- HDF board
- Hardboard
- OSB board
- Particleboard
- Plywood
- Composite materials

Applications

■ After the Press

In the wood based industry, ultrasonic measuring systems are combined with GreCon Thickness Gauges DMR 6000 and Board Scales to Quality Assurance Stations TRI. An optimum evaluation of the production process is achieved by measuring the cool panel. For this purpose, a UPU system is installed after the last cooling zone.

■ On the Sanding Line

For final quality control of the finished wood based panel, the UPU 6000 is installed after the sanding line.

Large application range of the UPU 6000

